

Spicing technology: Fitting tools for mechanical fasteners

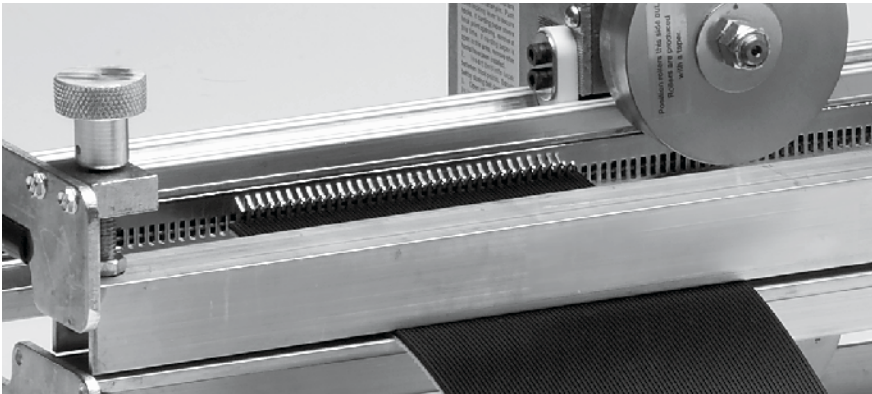

Brief outline

Simple fitting tool for continuous insertion of wire hook fasteners with idler roller. Can be used for different types of fastener. Belt can be moved.

Applications

- Belt thicknesses of 1.5 – 9 mm
- Belt widths max. 1200 mm in one step; unlimited because belt can be moved.
- Can be used in all industries and segments
- For all belts without having to de-install parts of conveyor; quick to insert and take out; especially for belt repairs

Supplied as

Basic tool without combs and mechanical fasteners

Accessories

- Combs
- Mechanical fasteners

Spare parts

No spare parts available

Tools can be sent for repair to the Forbo Siegling service department. You can also lease tools on request.

Contents

Preparation tools

- for cutting
- for splitting/peeling
- for grinding
- for punch cutting

Splicing tools

- for bonded splices – heating presses
- for melt splices – heating clamps
- for melt splices – heating presses
- for melt splices – special heating tools
- for mechanical fasteners

Fitting tools for mechanical fasteners

Type designation	SC-RL-0/350	SC-RL-0/600	SC-RL-0/1200
	Rolled splice tool	Rolled splice tool	Rolled splice tool
Technical data			
Dimensions (l x w x h)	[mm] 430 x 570 x 380	430 x 830 x 380	430 x 1470 x 380
Working width	[mm] 350	600	1200
Weight	[kg] 11.2	14.7	22.3
Article nos. basic tool			
	873037	873038	873039
Article nos. accessories			
Comb SC-FS-XXX-1 for HS14, HS15, HS16, HS17, HS18, HS19	873040	873044	873048
Comb SC-FS-XXX-2 for HS01 and HS12	873041	873045	873049
Comb SC-FS-XXX-3 for HS05, HS06 and HS11	873042	873046	873050
Comb SC-FS-XXX-4 for HS09	873043	873047	873051
Mechanical fasteners HS01	880468	880468	880468
Mechanical fasteners HS05	881501	881501	881501
Mechanical fasteners HS06	881502	881502	881502
Mechanical fasteners HS09	881503	881503	881503
Mechanical fasteners HS11	881504	881504	881504
Mechanical fasteners HS12	880450	880450	880450
Mechanical fasteners HS14	881506	881506	881506
Mechanical fasteners HS15	881507	881507	881507
Mechanical fasteners HS16	881508	881508	881508
Mechanical fasteners HS17	881861	881861	881861
Mechanical fasteners HS18	881862	881862	881862
Mechanical fasteners HS19	881863	881863	881863
Tool sheet no.			
	T-055	T-055	T-055

Type key

SC - RL - 0 / 350

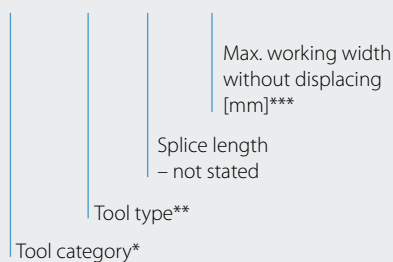

- * SC = fitting tools for mechanical fasteners
- ** RL = rolled splice tool
- FS = comb

For the combs the additional designation means

- 1 = HS14, HS15, HS16, HS17, HS18, HS19
- 2 = HS01, HS12
- 3 = HS05, HS06, HS11
- 4 = HS09

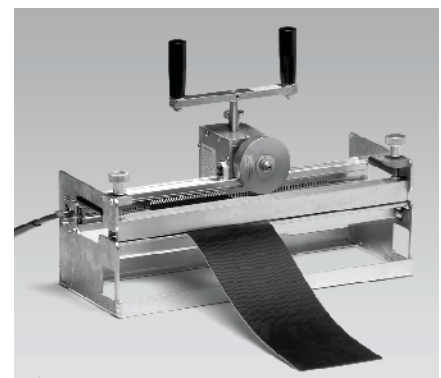

SC-RL-0/350



MOVEMENT SYSTEMS

Forbo Siegling GmbH
Lilienthalstrasse 6/8, D-30179 Hannover
Phone +49 511 6704 0, Fax +49 511 6704 305
www.forbo-siegling.com, siegling@forbo.com

Forbo Movement Systems is part of the Forbo Group,
a global leader in flooring, bonding and movement systems.